

# Technical Details



Max. width for single system	13000mm
Max. projection for single system	14000mm LT / 22000mm XL
Max. size	182 sqm LT / 286 sqm XL
Rafter profile dimension	80mm x 125mm LT / 110mm x 160mm XL
Rafter profile design	Curved
Gutter profile dimension	166mm x 160mm
Post dimension	100mm x 130mm
Min. rafter inclination	7 °
Surface finishing	Electrostatic powder-coating
Motor type	220 VAC 50Hz tubular motor 85, 120 NM direct drive
Automation	included
Control unit	included
Standard High Power Led lighting	optional
Hdd Lux High Power Led lighting	optional
Dimmer	optional
Blackout fabric	included*
Top cover	included
Aerofoil louvre	optional
Side channel cover profile	N/A
Overhang	optional
Decorative fabric	optional
Rain sensor	optional
Wind sensor	optional
Sun sensor	optional
Wind&Sun Sensor	optional

\*N/A (not available)

\*Please ask for available fabric color options.

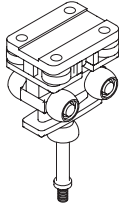

### F3 Eight wheel slider

Four horizontal & four vertical rollers working together for perfectly smooth operation every time. The F3 eight wheel system is proven to remove the jamming issue that occurs with the 4 wheel system and can take loads of upto 600KG.

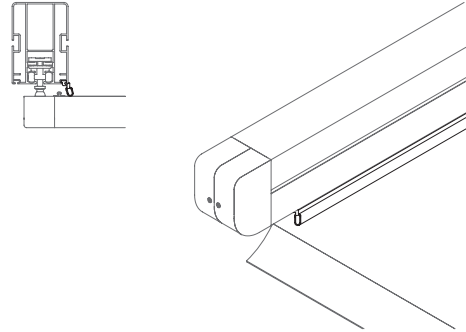

### Rafter stormguard edge seal

The rafter Stormguard edge seal stops water from dripping over the side of the system by providing a soft cushioning barrier along the side of the system.

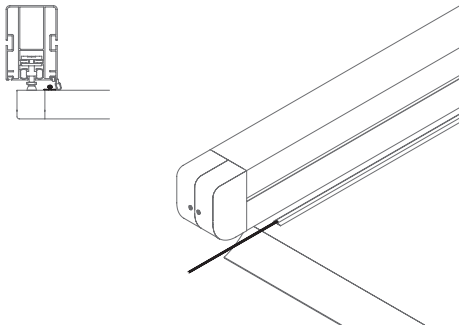

### Fabric anti-drop edge cord with electrical cable

The fabric anti-drip edge cord with integrated lighting electrical cable works in conjunction with the Stormguard edge seal to prevent any water leaks over the side of the system.

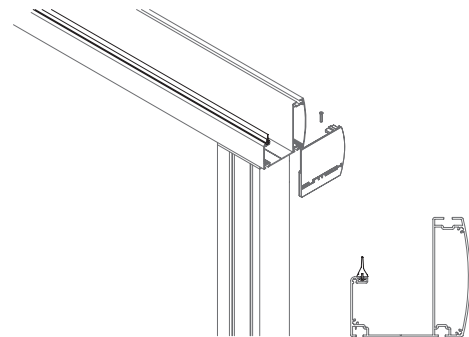

### Gutter stormguard seal

The Stormguard gutter seal provides a perfect seal to prevent water leaks along the front of the system from driving rain or splashing from the gutter.

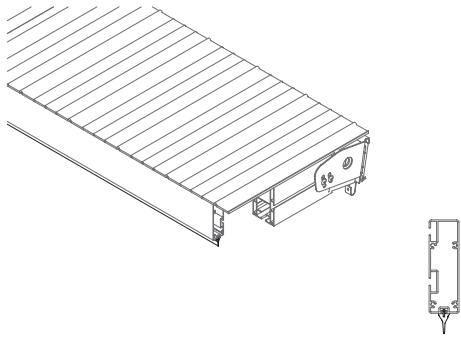

### Hood stormguard seal

The Stormguard hood seal provides the perfect seal to prevent driving rain&wind coming in under the hood profiles.

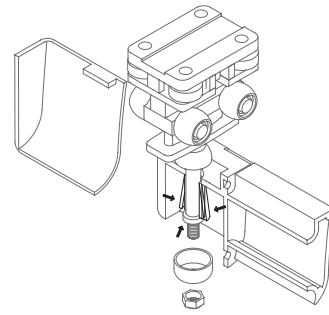

### F3 slider easy clip installation

The F3 system has been designed for ease of use, to save time on installations and reduce the number of staff required. Each F3 slider can take loads of upto 600KG once in place.

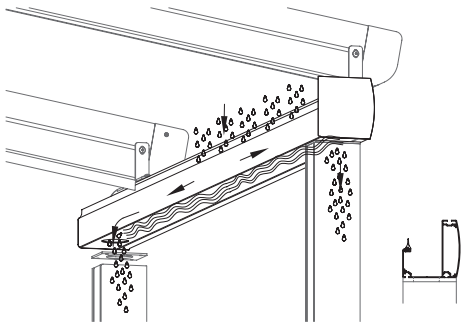

### Integrated gutter & internal drainage system

The integrated gutter system provides the perfect solution for water drainage.

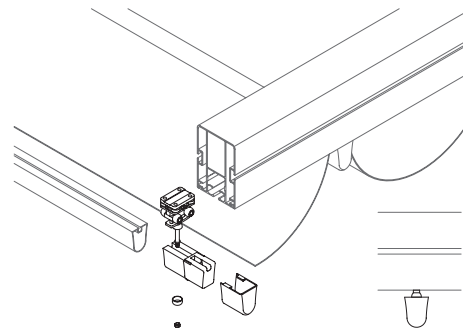

### F3 slider and fabric profile assembly

The system has been designed for ease of assembly to save time on installations and reduce the number of staff required.

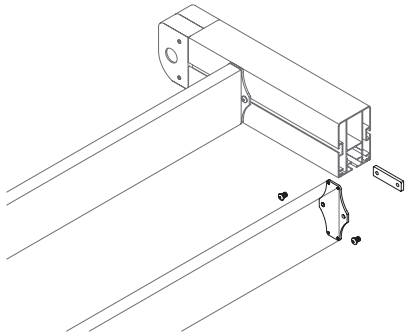

### Motorbox support & hood support profile easy installation

Each support profile is easy to install and simple to adjust at the time of installation.

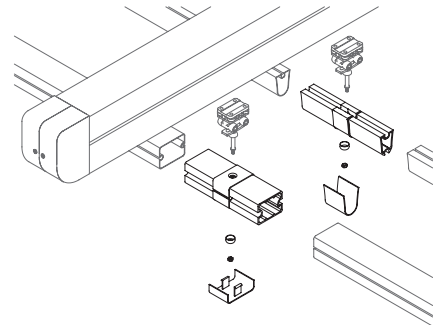

### Easy clip intermediate joints (for 2 & 3 module systems)

The Easy clip intermediate joints have been designed for ease of site assembly to save time and reduce the number of staff required.

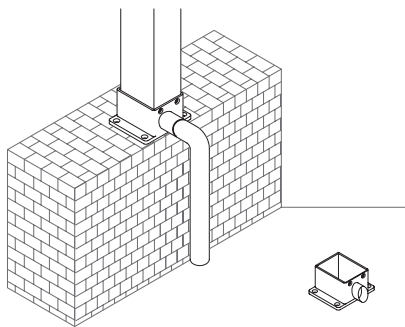

### Base plate with external spout

This base plate provides a water dispersal solution.

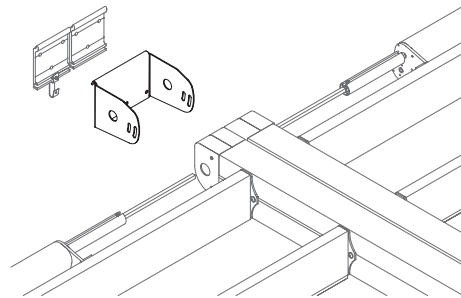

### Double rafter hang bracket kit

An advanced solution for installing two rafters at once.

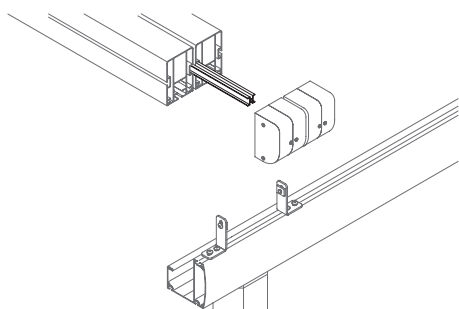

### Storm channel for joining system

The storm channel is patented solution for joining two systems side by side with a waterproof join.

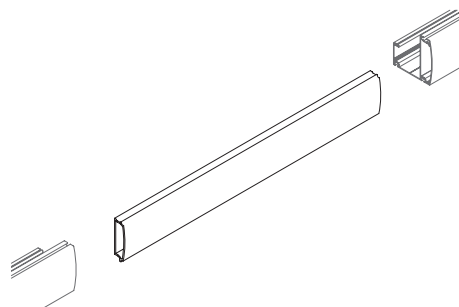

### Gutter profile joining bar

A smart solution for joining the gutter profiles.

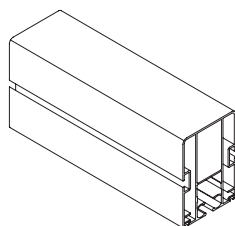

### Rafter profile with side channels for easy installation

The Suntech rafter profiles are designed with functional side channels for easy installation.

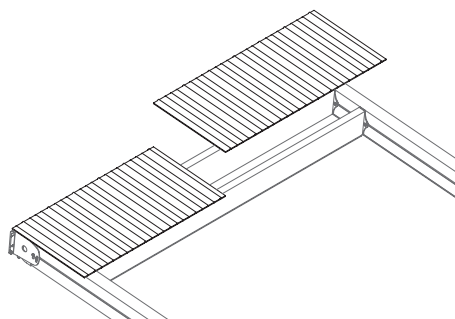

### Hood profile sheets

Suntech's hood profile sheets provide an attractive covering solution for the system when not in use. The low profile aesthetic design offers additional protection to the system with a chic touch.

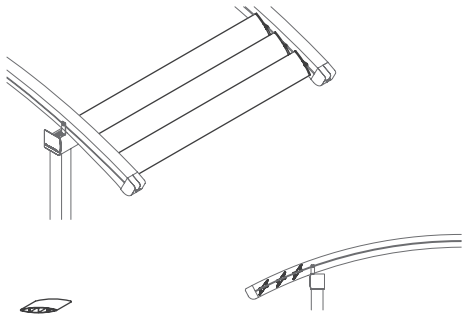

### Aerofoil Louvres

The addition of Aerofoil louvres can provide added shade when the system is closed.

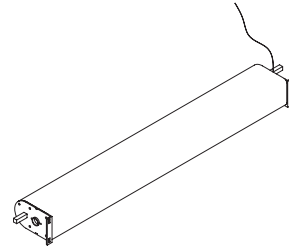

### Compact 26rpm direct drive motor box

The Suntech direct drive motor system is a quick and efficient system that drives all conveyor rafters at the same time. The low profile design also allows the fabric to be stored underneath the motor which saves additional space.

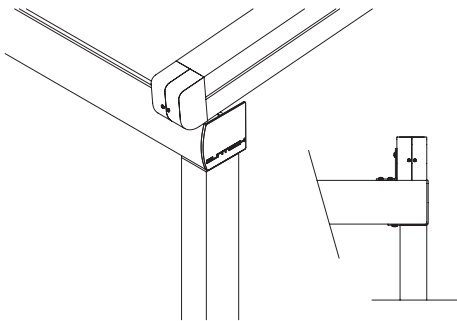

### Gutter flush with rafter

Gutter solution when the system is installed next to a wall or no overhang of the gutter is required.

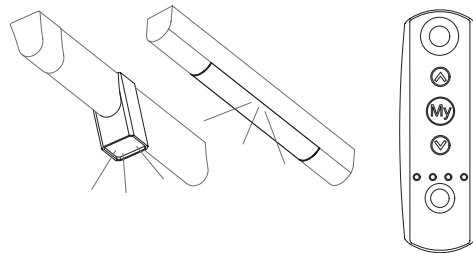

### LED-TECH dimmer setup

LED-TECH dimmer lighting is an integrated lighting solution that can be added to any Suntech systems.

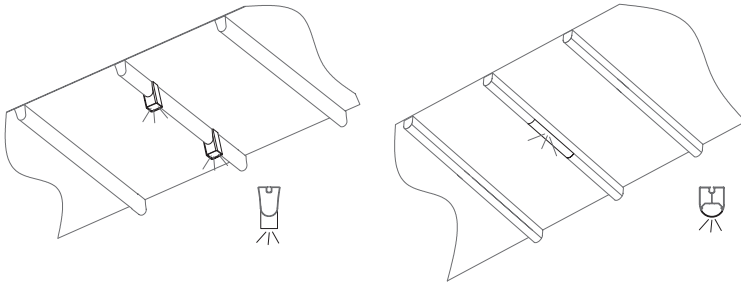

### LED-TECH high powered lighting

LED-TECH lighting is an integrated lighting solution that can be added to any Suntech system.

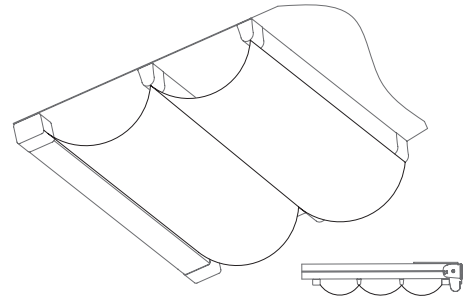

### Decorative fabric under layer

The second decorative fabric under layer of fabric can provide an elegant touch of design.